

# Motion control made easy

## Day 6 Backlash compensation

### Topics of discussion:

- ✓ Single loop
- ✓ Standard dual loop (Std. Firmware)
- ✓ Improved dual loop (Custom F/w)
- ✓ Comparing results

“All work and no play makes Jack a dull boy,” but in a motion control system it can be a good thing. Play — mechanical backlash — in the coupling between the motor and load is a major source of position errors. Whether it’s caused by a gearhead, leadscrew, or other component, it poses a serious design dilemma: Where do you put the position sensor?

Most designers place the sensor on the motor shaft. While this ensures precise motor position, it does so at the expense of load position. Naturally, the greater the backlash beyond the motor shaft, the further off the load is likely to be.

The alternative, placing the sensor on the load, presents another set of problems. Here, backlash becomes part of the closed loop, and hence, system dynamics. The dynamic response of backlash itself, essentially a delay, makes the position loop less stable and prone to oscillation.

### Standard dual loop

One way around this impasse is to place a position sensor on either side of the coupling. The two devices tell the controller the exact position of both the motor and load so the control algorithm can operate more intelligently.

The standard “dual loop” control topology, Figure 1, splits the PID compensation filter into two parts. The proportional and integral terms operate on the signal coming from the load, forming the main feedback loop. The derivative term acts on motor position, the best source of information for stabilizing the system.

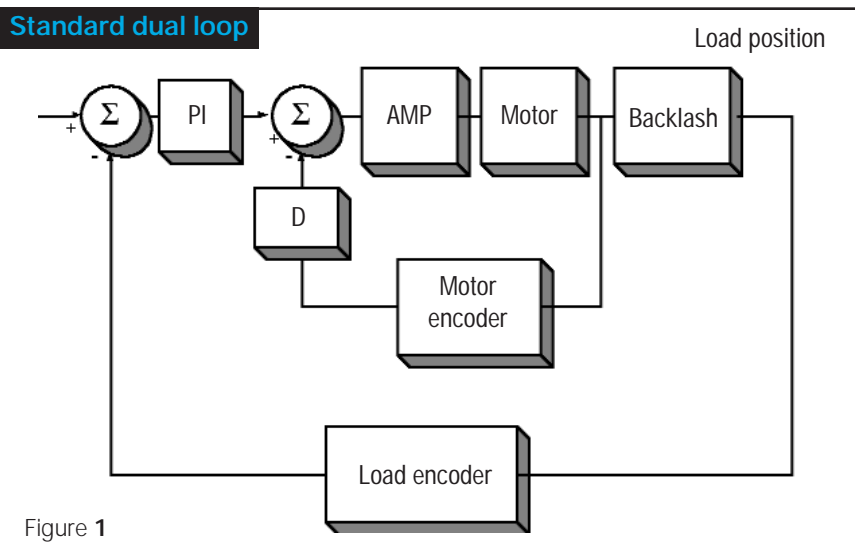

Figure 1

One way to compensate for backlash is to place position sensors on either side of the motor-load coupling. The standard dual-loop method splits the PID compensation filter into two parts, with the PI terms in the signal path coming from the load and the D term acting on motor position.

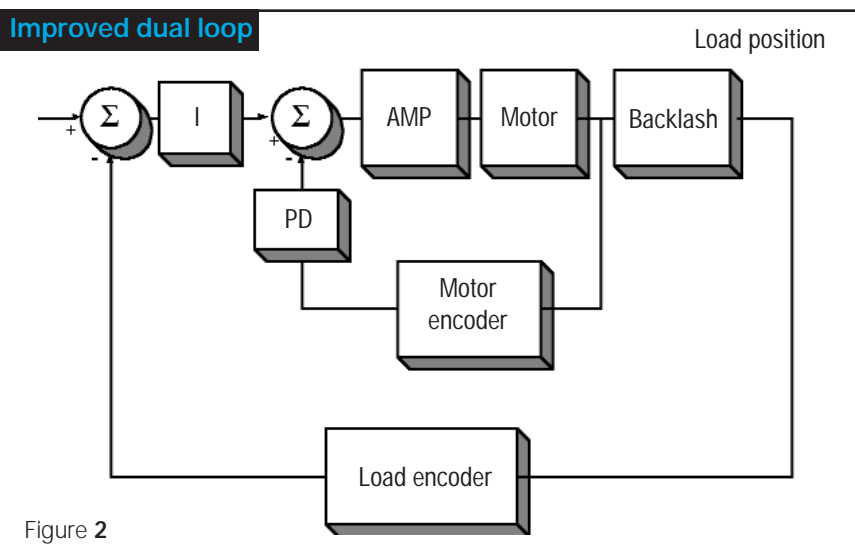

Figure 2

By moving the P term from the outer to the inner loop, where it has greater influence on stability, the improved dual-loop method achieves fast, precise response despite large backlash.

This approach has been in use for several years and is proven at making systems more stable. It is limited in speed, however, which has researchers searching for an even better method.

### Improved Dual Loop

Through experimentation, motion system engineers have devised a speedier version of dual loop control. The improvement (see Figure 2) stems from how the PID filter is divided. The integral term operates alone in the outer (load) loop, while the proportional and derivative terms work together in the motor feedback (inner) loop. Although experiments clearly and consistently indicate that this technique is more responsive than standard dual-loop control, it is not obvious why.

One line of reasoning conjectures that the load-sensor loop includes the backlash and is therefore less stable. From this, it intuitively follows that the inner loop, incorporating the motor encoder, stabilizes the system, while the outer loop causes in-

### Comparing compensation techniques

System variable	Single loop	Standard dual loop	Improved dual loop
$K_D$	6	200	800
$K_P$	4	9	50
$K_I$	0	1	10
$t$ (msec)	$\infty$	520	142

stability. To improve system stability, then, it's advisable to increase the gain — and relative influence — of the stable loop, which is essentially what happens when the P term moves from the outer to the inner loop.

### Comparing results

To show how the various compensation methods stack up, each is applied to a system with an exaggerated amount of backlash ( $10^\circ$ ) between the motor and load. By rotating the load  $90^\circ$  to a target position and measuring settling time, it's possible to make a quantitative comparison.

The attached table says it all. The improved dual-loop method is the obvious winner, converging in just 142 msec. By

contrast, the single loop method, using only a load encoder, never even reaches the required target. Reading between the lines, the delay due to backlash fouled up the integrator, causing it to make the filter unstable, and thus, unable to rid the system of steady state error. Standard dual-loop control, although it at least settled the load, took almost four times longer than the improved method.

*Dr. Jacob Tal is president and cofounder of Galil Motion Control Inc., Rocklin, Calif. He can be reached at (800) 377-6329 or [jacobt@galilmc.com](mailto:jacobt@galilmc.com).*

**Circle 363** if you liked this article.

## leading the way in linear motion

provide smooth motion and accurate travel in a wide range of applications.

Our new line of miniature ball screws are ideal for Optical Instruments, Inspection Equipment and Medical applications. The precision miniature ball screws are custom engineered to meet your design specifications and are available in light pre-load, anti-backlash and controlled backlash.

Diameters range from 6mm to 125mm and leads from 2mm to 40mm. English equivalents are also available.

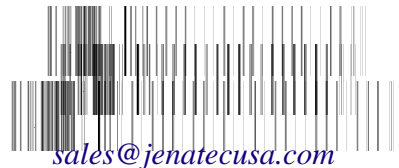

**JENA**  
**TEC**

1-888-4-JENA-TEC

